

PIG RECEIVER SPECIFICATIONS

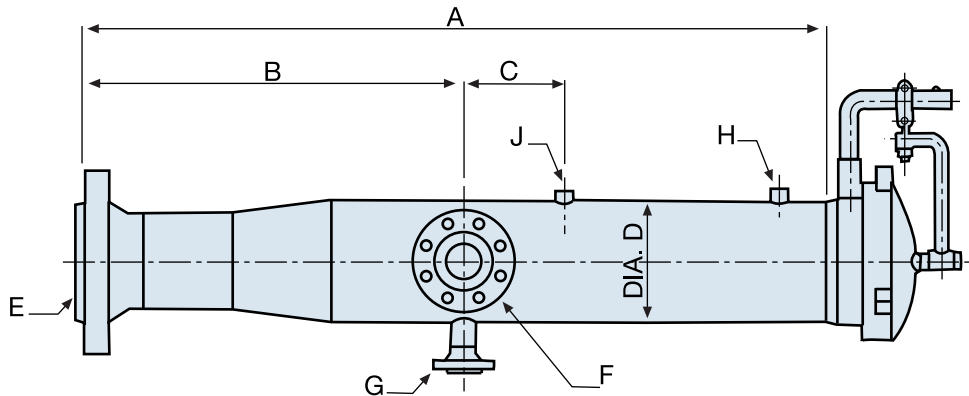

CUSTOMER		SHEET		
PROJECT		SPEC. No.	REV	
REFERENCE		CONTRACT	DATE	
EQUIPMENT NAME		QUOTATION No.		
TAG NO.		BY	CHK'D	APPR.

BASIC LAYOUT (NOT TO SCALE)



VESSEL DESIGN CHARACTERISTICS

DESIGN CODE		PROVISIONAL DIMENSIONS				
ASME CODE STAMP		A				
DESIGN PRESSURE		B				
DESIGN TEMPERATURE		C				
MIN. DESIGN METAL TEMP.		D				
RADIOGRAPHY		NOZZLE SCHEDULE				
MAG PARTICLE INSPECTION		ITEM	QTY	SIZE	RATING	SERVICE
CORROSION ALLOWANCE		E				OUTLET
HYDRO-TEST PRESSURE		F				KICKER
		G				DRAIN
		H				GAUGE
		J				VENT
MATERIALS	BARREL					
	FLANGES					
	FITTINGS					
	NACE					
SUPPORT SADDLES						
JAMISON MODEL NUMBER						

NOTES: