

MODEL JMBF-150

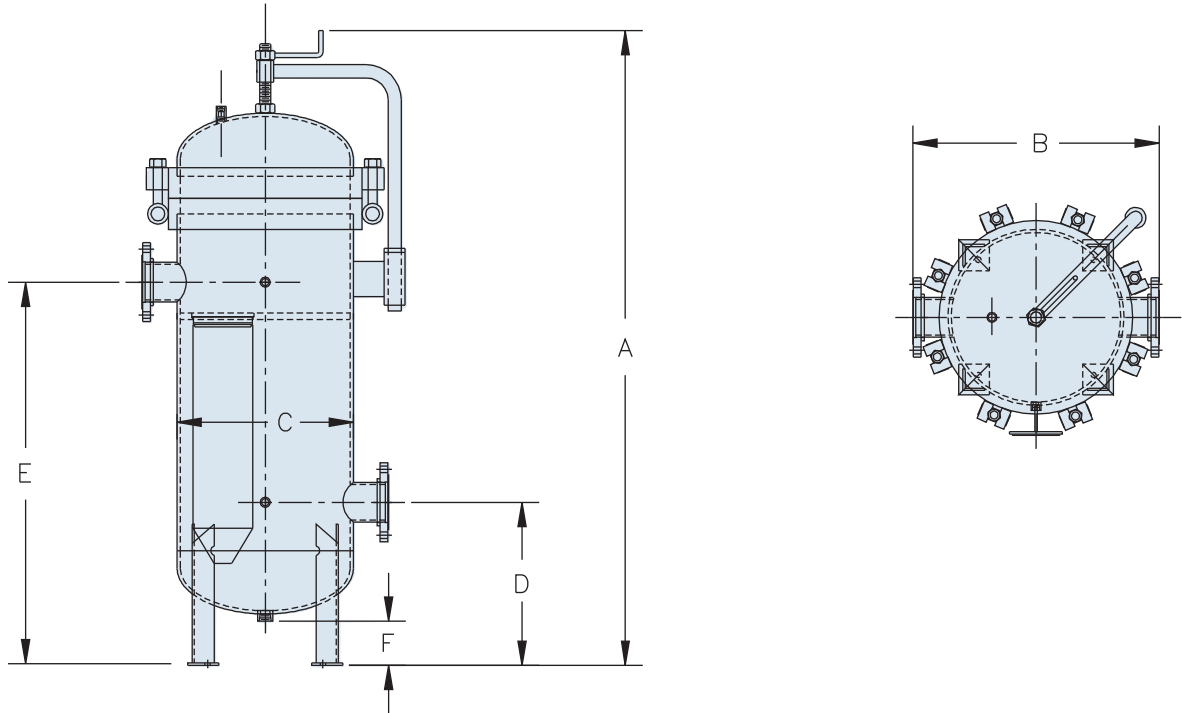

150 PSI MULTI-BAG FILTER



Standard Features:

- * Quick Open Cover
- * 150 psi at 100 degrees F design
- * ASME VIII Div 1 Design code
- * 1/2" NPT Vent and 1" NPT Drain
- * Buna-N Cover O-Ring
- * Differential Pressure gauge connections
- * Support Legs

Options:

- * Stainless Steel, Alloy materials
- * Hinged Cover
- * U-Stamp certification
- * DP gauge/switch (fitted)
- * Air release heads (fitted)
- * Cad. Plated Bolting
- * Weld neck flanges
- * Perforated Baskets with Mesh Liners
- * Flanged Vents and Drains
- * Additional ancillary connections

Model	Inlet & Outlet	Qty of Bags	A	B	C	D	E	F	Approx. Weight lbs.
JMBF-150-3-3	3"	3	66"	26"	18"	17"	45"	5"	550
JMBF-150-4-4	4"	4	66"	28"	20"	17"	45"	5"	650
JMBF-150-4-5	4"	5	70"	30"	22"	18"	45"	5"	760
JMBF-150-6-6	6"	6	72"	32"	24"	18"	45"	5"	880
JMBF-150-6-7	6"	7	74"	36"	26"	20"	45"	5"	970
JMBF-150-8-8	8"	8	77"	36"	28"	22"	48"	6"	1390
JMBF-150-8-10	8"	10	80"	42"	32"	23"	50"	6"	1690
JMBF-150-10-14	10"	14	84"	46"	36"	25"	52"	6"	1800
JMBF-150-12-18	12"	18	88"	52"	42"	27"	54"	6"	2500

Notes:

Dimensions for guidance only, please request certified drawings.
 Larger sizes and pressure ratings available upon request.
 Special application requirements can be incorporated on request.
 Dimensions in inches.