

ANSI 600#RF BASKET STRAINER

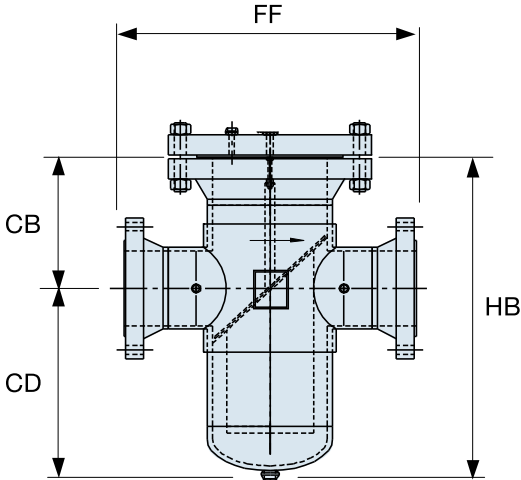

MODEL FB - BOLTED COVER

Standard Features:

- * Bolted Blind Flange Cover
- * 1/8" Perforated Basket
- * NPT Vent (1/2") and Drain
- * ANSI B31.4 Design
- * NAF Cover Gasket

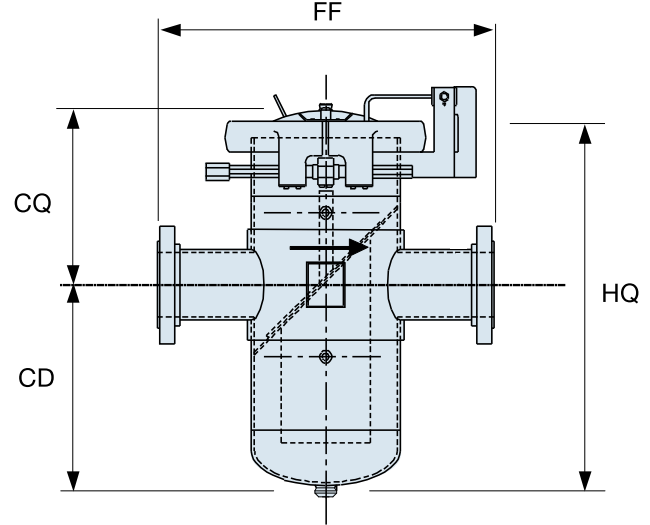

MODEL FQ - QUICK OPEN COVER

Standard Features:

- * Quick Opening Closure
- * 1/8" Perforated Basket
- * NPT Vent (1/2") and Drain
- * ANSI B31.4 Design
- * Buna O-Ring

Line Size	Body Dia	FF	CD	CB	HB	Drain NPT	CQ	HQ	FB Weight lbs	FQ Weight lbs
2	4-1/2	17	8	7	15	3/4	na	na	132	na
3	6-5/8	20	12	8	20	3/4	11	23	272	155
4	8-5/8	24	14	9	23	3/4	13	27	451	290
6	10-3/4	28	18	10	28	1	14	32	782	535
8	12-3/4	32	21	12	33	1	17	38	1077	765
10	14	34	24	14	38	1	19	43	1416	1050
10	16	36	24	14	38	1-1/2	20	44	1754	1280
12	16	38	24	16	40	1-1/2	22	46	1917	1445
12	18	42	28	17	44	1-1/2	23	51	2281	1730
14	18	44	29	17	45	1-1/2	23	52	2413	1865
16	20	48	30	18	48	2	25	55	3152	2455
16	24	52	39	20	59	2	28	67	4355	3275
18	24	54	39	20	59	2	28	67	4560	3480
20	24	56	43	24	67	2	32	75	5029	3950
20	30	60	51	30	81	2	40	91	5762	5305
24	30	62	51	30	81	2	40	91	6505	6045

Options:

- * Stainless Steel, Alloy materials
- * Hinged Cover
- * Cover Davit
- * ANSI B31.3, 4 or ASME VIII Div 1
- * U-Stamp certification

- * Support Legs or skirt
- * DP gauge connections
- * DP gauge/switch (fitted)
- * Air release head (fitted)
- * Cad. Plated Bolting
- * Spiral Wound Gasket

- * Weld Neck Flanges
- * Larger Perf or Mesh liners
- * Replaceable mesh liner
- * Flanged Vent and Drain
- * Heavy duty baskets and wedge wire
- * Blow-down basket

Notes:

Dimensions for guidance only, please request certified drawings.
 Larger sizes and pressure ratings available upon request.
 Special application requirements can be incorporated on request.
 Lower pressure drop designs available on request.
 Dimensions in inches.